

Dimension of MJP-0.6-T

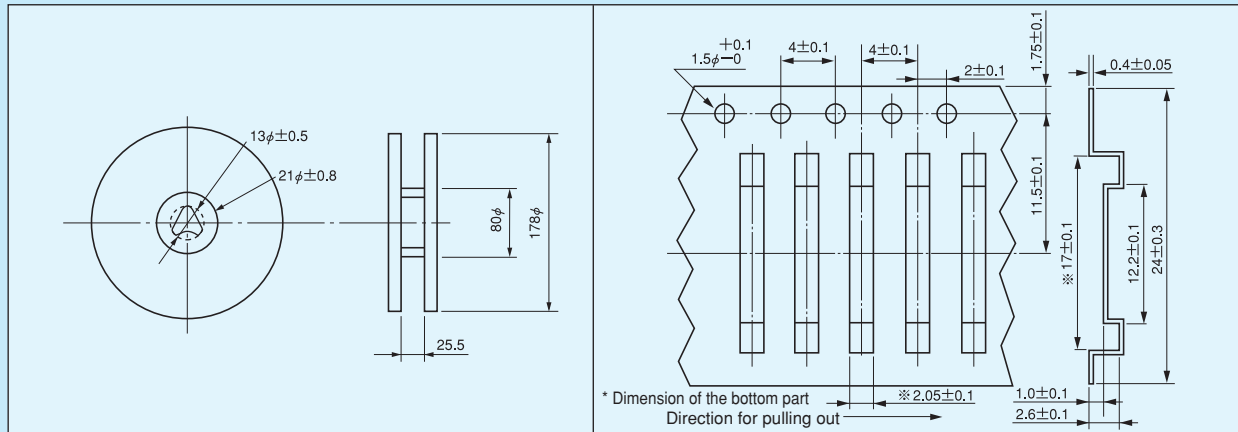

Dimension of MJP-0.7, 0.8, 1.0-T

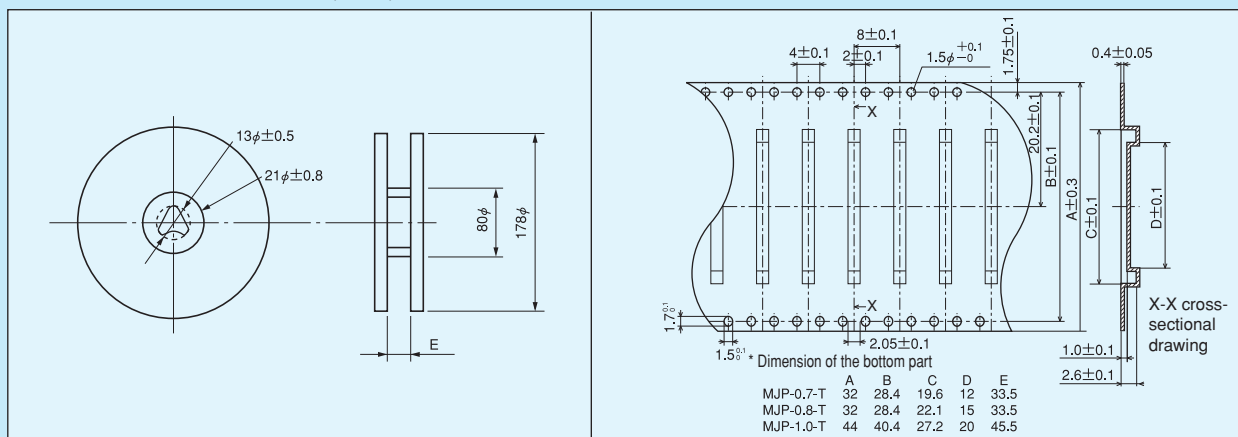

Jumper wire for surface mounting (manual soldering type) [Part number: MJH-18] (1000pcs/pack)

For surface mounting

- This can connect surface mounting boards in the horizontal direction by manual soldering.
- Material: Phosphor bronze
- Finish: Tin plating over nickel base
- Rated current: 7A



Example of usage

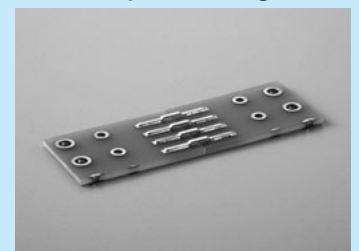

Recommended land diameter

